

All dimensions are in MM unless stated

UNLESS OTHERWISE SPECIFIED: DIMENSIONS ARE IN MILLIMETERS				FINISH:		DEBURR AND BREAK SHARP EDGES		DO NOT SCALE DRAWING		REVISION	
SURFACE FINISH:											
TOLERANCES:											
LINEAR:											
ANGULAR:											
	NAME	SIGNATURE	DATE					TITLE: Bottom Bracket shell			
DRAWN	Roman Mich										
CHK'D											
APPV'D											
MFG											
Q.A						MATERIAL:		DWG NO. 1		A3	
								SCALE:1:1		SHEET 1 OF 1	
						WEIGHT:					

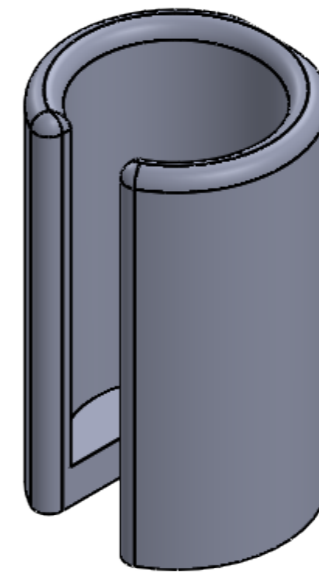
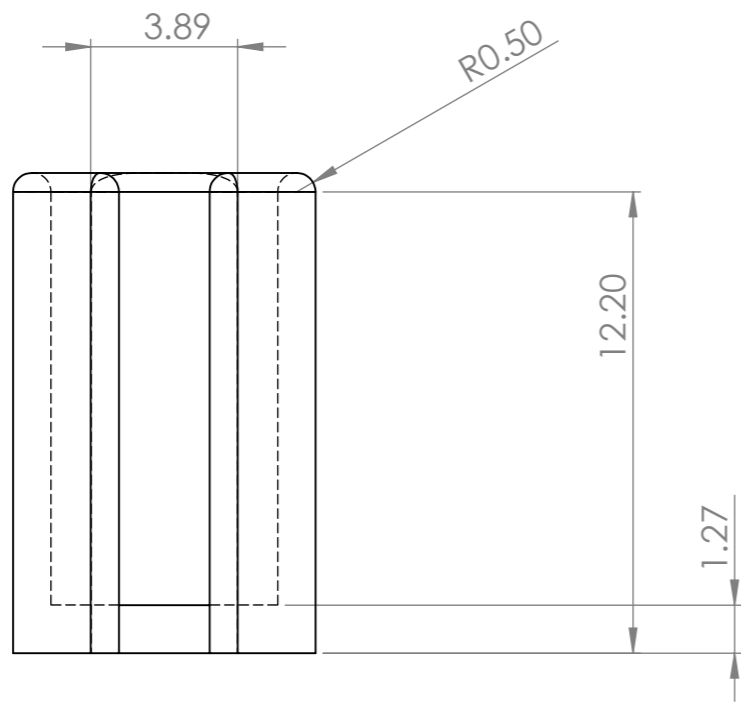
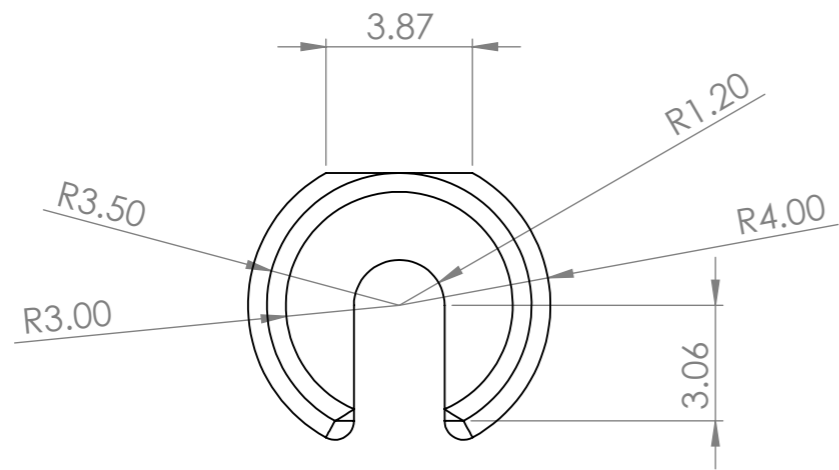

All dimensions are in MM unless stated

UNLESS OTHERWISE SPECIFIED: DIMENSIONS ARE IN MILLIMETERS SURFACE FINISH: TOLERANCES: LINEAR: ANGULAR:				FINISH:		DEBURR AND BREAK SHARP EDGES		DO NOT SCALE DRAWING		REVISION	
DRAWN Roman MIAH				SIGNATURE		DATE		TITLE: Cable guide			
CHK'D											
APPV'D											
MFG											
Q.A						MATERIAL:		DWG NO. 9		A3	
						WEIGHT:		SCALE:5:1		SHEET 1 OF 1	

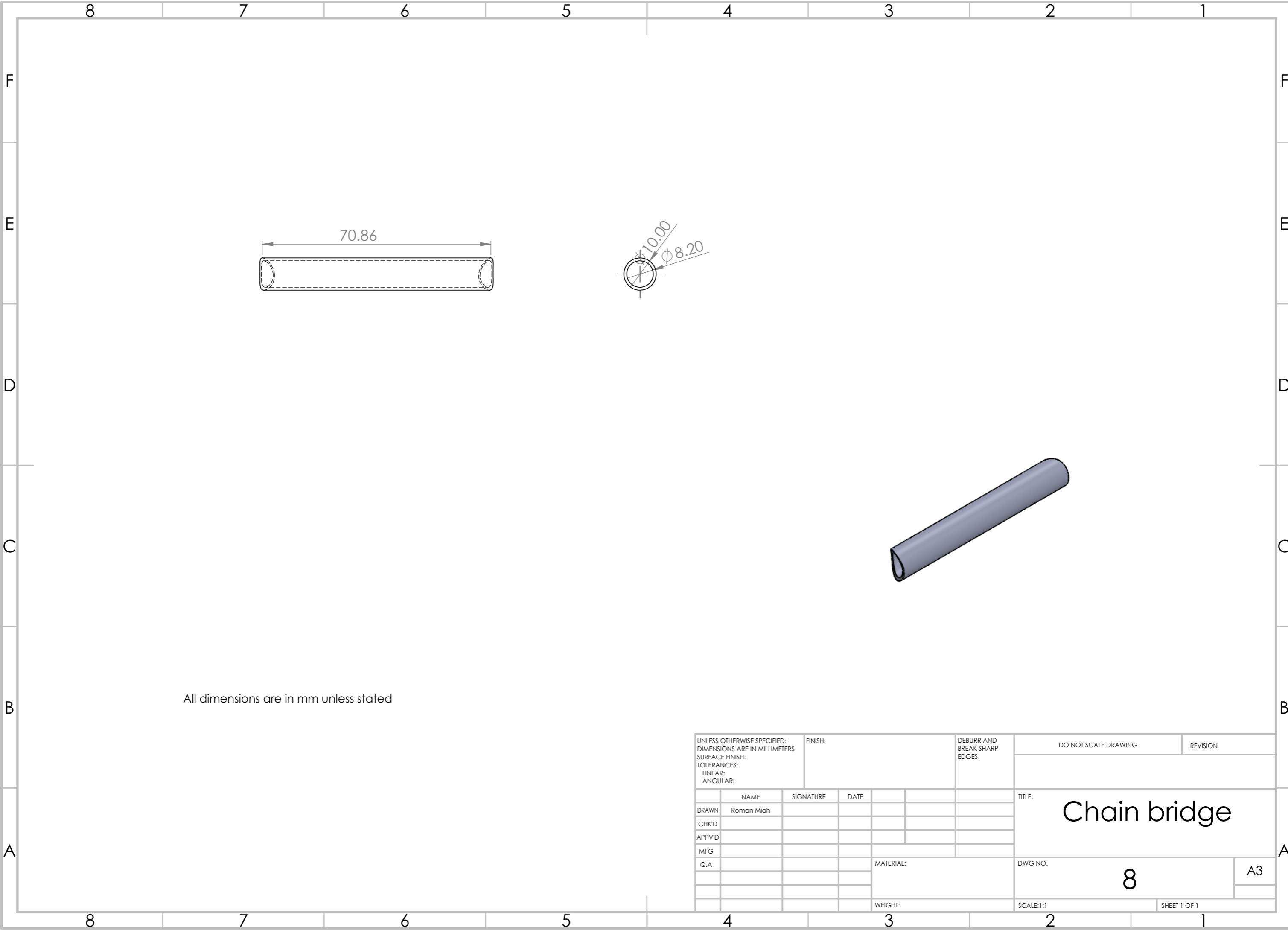

All dimensions are in mm unless stated

UNLESS OTHERWISE SPECIFIED: DIMENSIONS ARE IN MILLIMETERS				FINISH:		DEBURR AND BREAK SHARP EDGES		DO NOT SCALE DRAWING		REVISION	
SURFACE FINISH:								TITLE: <h1>Chain bridge</h1>			
TOLERANCES:											
LINEAR:											
ANGULAR:											
	NAME	SIGNATURE	DATE					DWG NO.		A3	
DRAWN	Roman Mich							8			
CHK'D											
APPV'D											
MFG											
Q.A						MATERIAL:					
						WEIGHT:		SCALE:1:1		SHEET 1 OF 1	

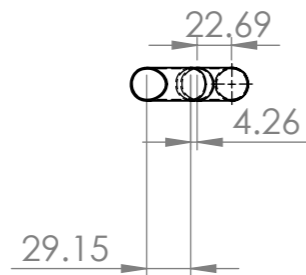
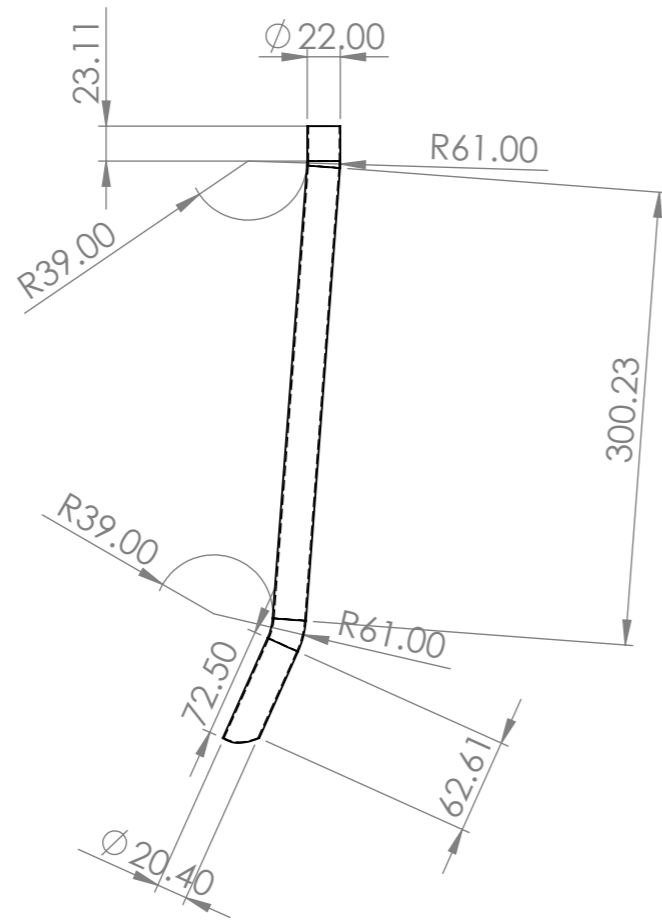

All dimensions are in MM unless stated

UNLESS OTHERWISE SPECIFIED: DIMENSIONS ARE IN MILLIMETERS SURFACE FINISH: TOLERANCES: LINEAR: ANGULAR:				FINISH:		DEBURR AND BREAK SHARP EDGES		DO NOT SCALE DRAWING		REVISION	
DRAWN Roman Mich				SIGNATURE		DATE		TITLE: Chain_stay			
CHK'D											
APPV'D											
MFG											
Q.A						MATERIAL:		DWG NO. 6		A3	
						WEIGHT:		SCALE:1:5		SHEET 1 OF 1	

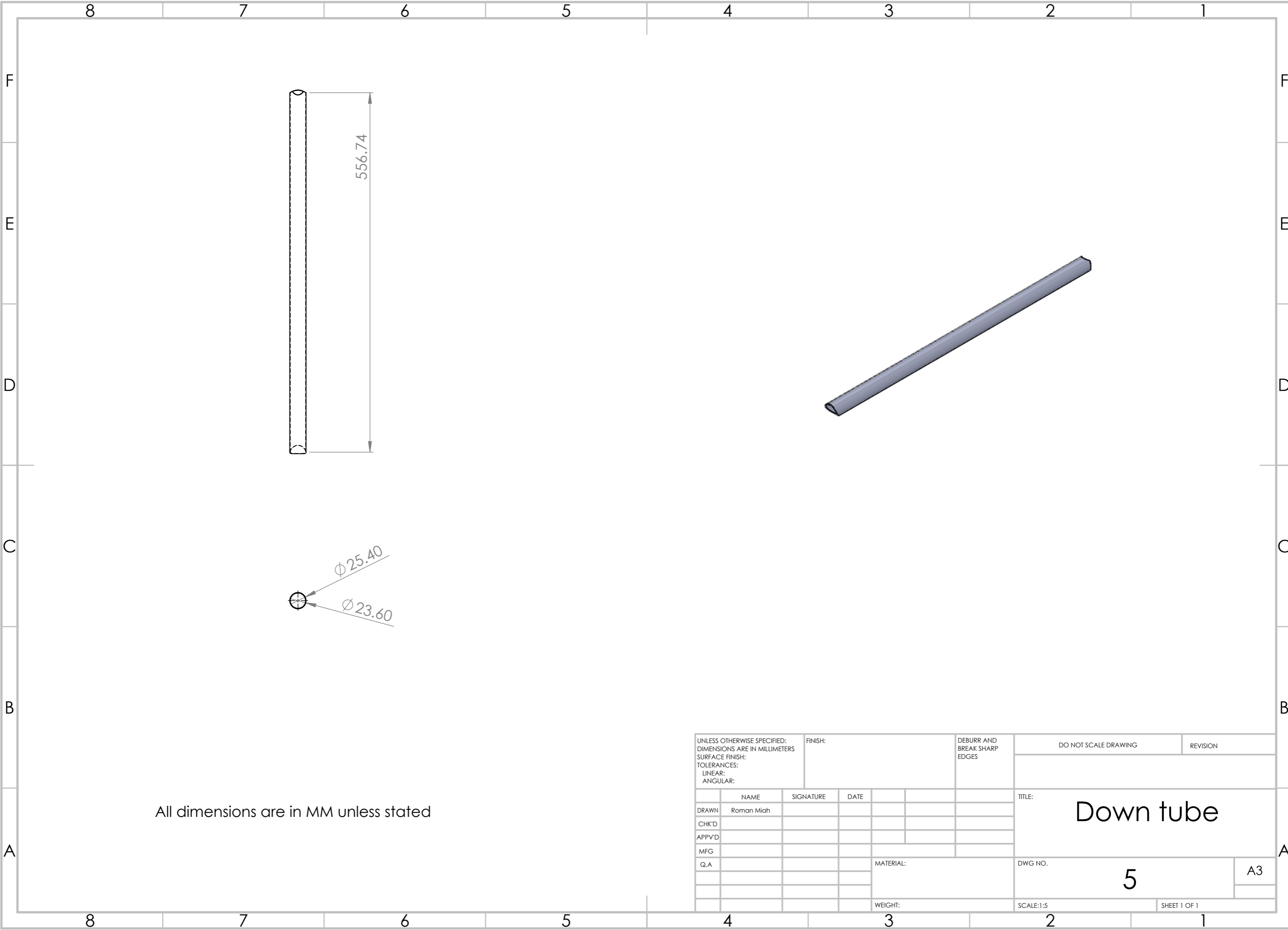

All dimensions are in MM unless stated

UNLESS OTHERWISE SPECIFIED: DIMENSIONS ARE IN MILLIMETERS SURFACE FINISH: TOLERANCES: LINEAR: ANGULAR:				FINISH:		DEBURR AND BREAK SHARP EDGES		DO NOT SCALE DRAWING		REVISION			
								TITLE: <h1>Down tube</h1>					
DRAWN				NAME		SIGNATURE						DATE	
CHK'D													
APPV'D													
MFG													
Q.A								MATERIAL:		DWG NO. <h1>5</h1>			
								WEIGHT:		SCALE:1:5			
										SHEET 1 OF 1			
										A3			

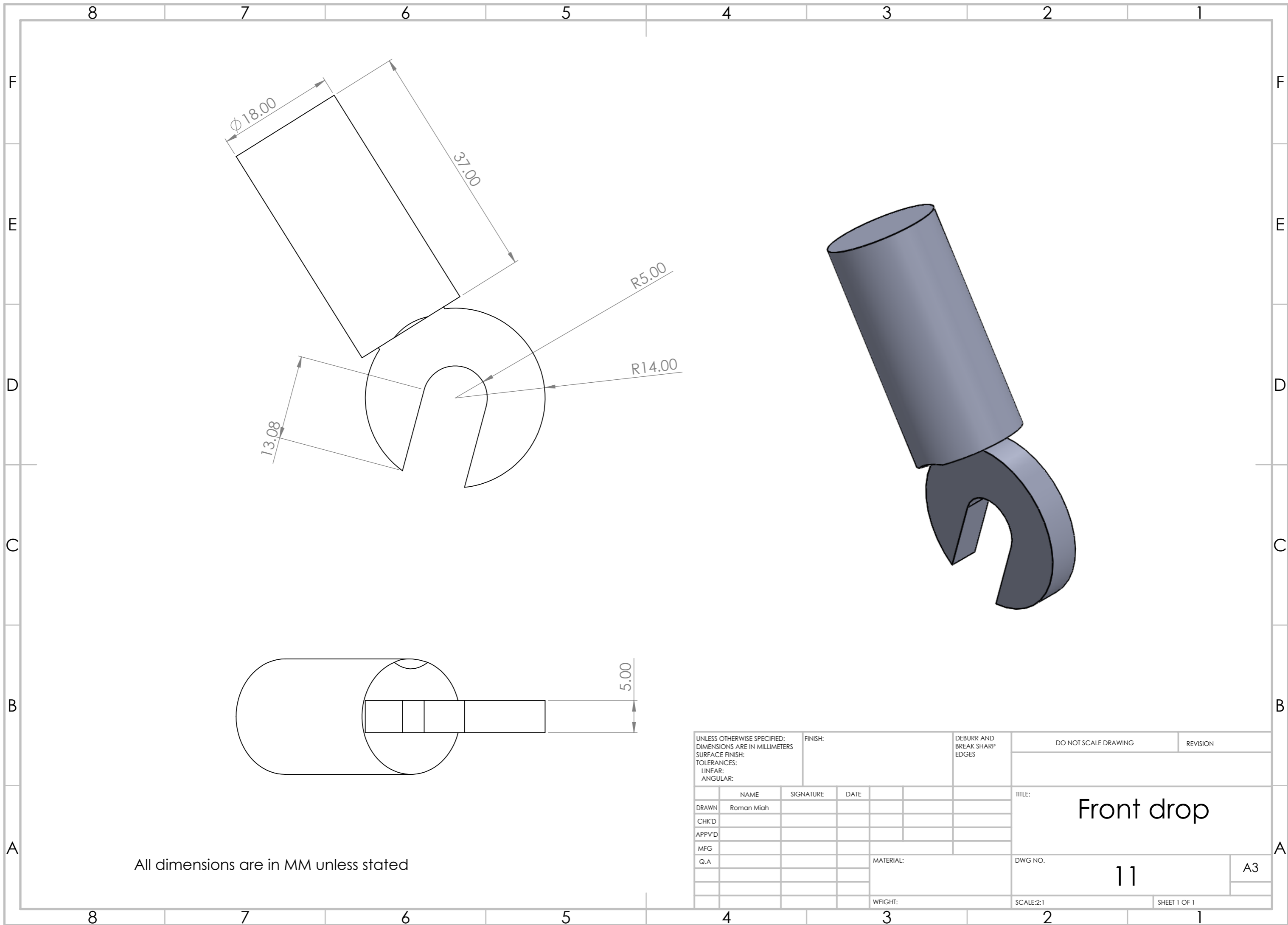

All dimensions are in MM unless stated

UNLESS OTHERWISE SPECIFIED: DIMENSIONS ARE IN MILLIMETERS SURFACE FINISH: TOLERANCES: LINEAR: ANGULAR:				FINISH:		DEBURR AND BREAK SHARP EDGES		DO NOT SCALE DRAWING		REVISION	
								TITLE: Front drop			
DRAWN Roman Mich				SIGNATURE		DATE		DWG NO. 11		A3	
CHK'D								SCALE:2:1		SHEET 1 OF 1	
APPV'D								MATERIAL:			
MFG								WEIGHT:			
Q.A											

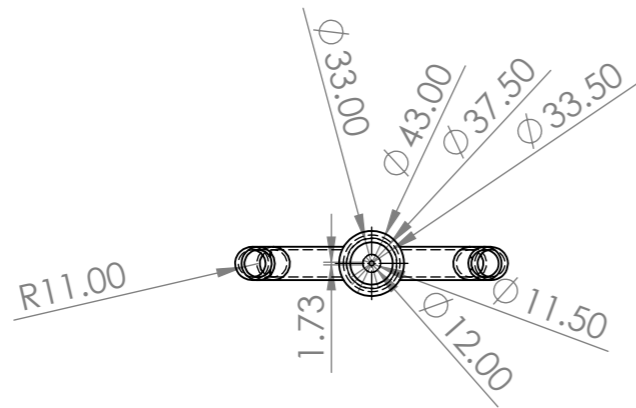
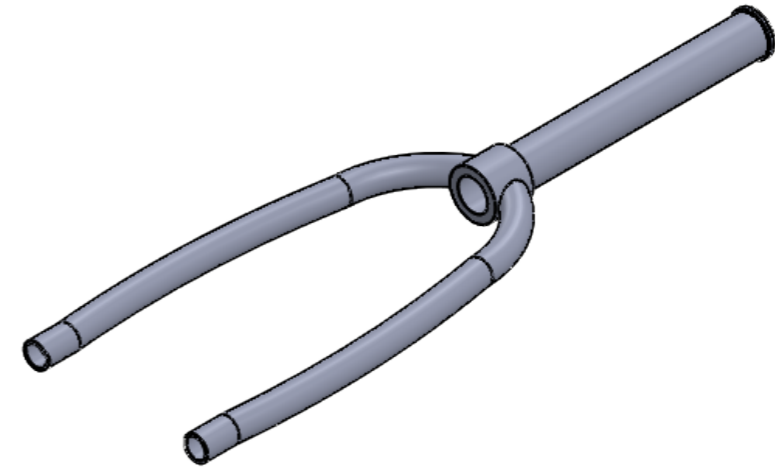
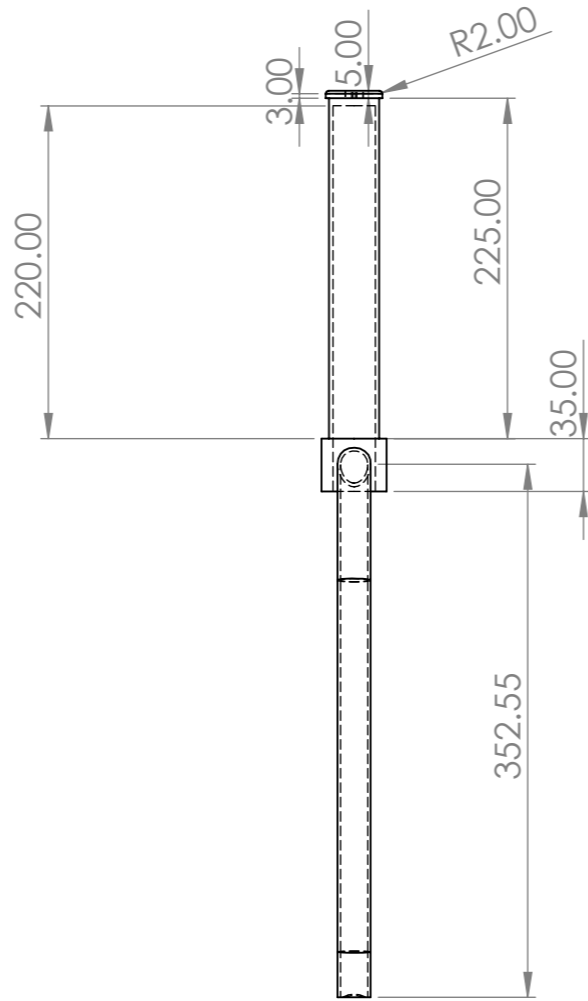
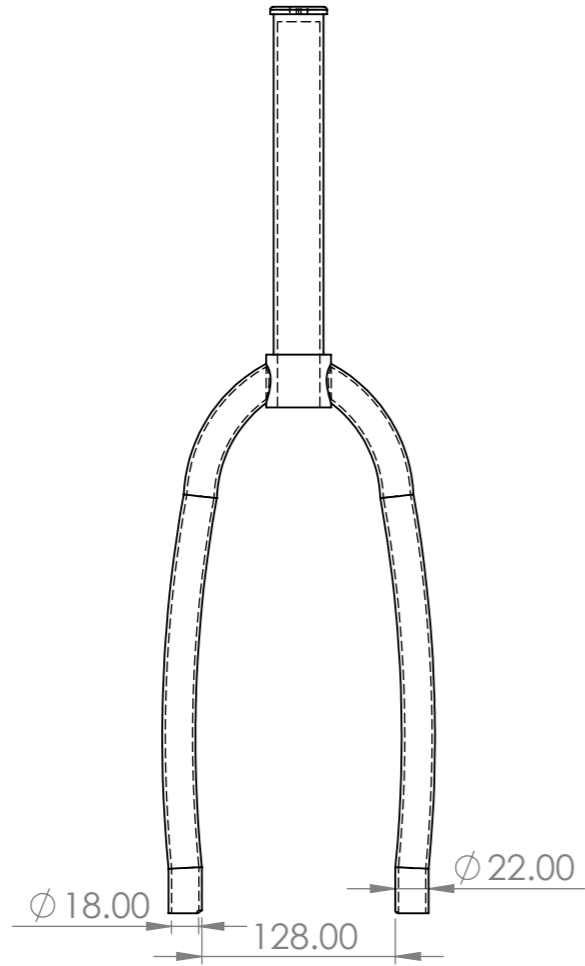

All dimensions are in MM unless stated

UNLESS OTHERWISE SPECIFIED: DIMENSIONS ARE IN MILLIMETERS SURFACE FINISH: TOLERANCES: LINEAR: ANGULAR:				FINISH:		DEBURR AND BREAK SHARP EDGES		DO NOT SCALE DRAWING		REVISION	
DRAWN Roman Mich				SIGNATURE		DATE		TITLE: Front structure			
CHK'D											
APPV'D											
MFG											
Q.A						MATERIAL:		DWG NO. 12		A3	
						WEIGHT:		SCALE:1:5		SHEET 1 OF 1	

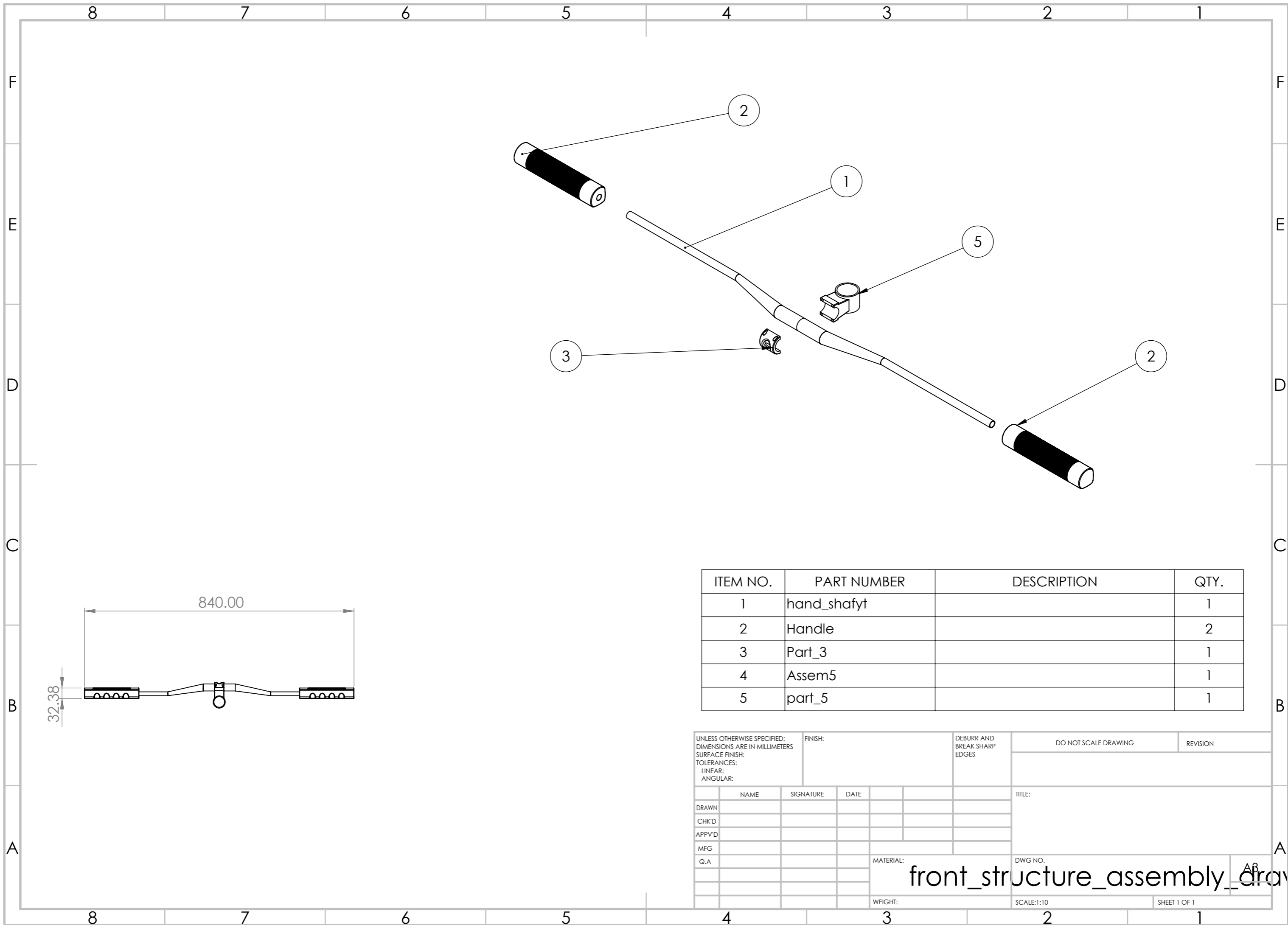

ITEM NO.	PART NUMBER	DESCRIPTION	QTY.
1	hand_shafyt		1
2	Handle		2
3	Part_3		1
4	Assem5		1
5	part_5		1

UNLESS OTHERWISE SPECIFIED: DIMENSIONS ARE IN MILLIMETERS SURFACE FINISH: TOLERANCES: LINEAR: ANGULAR:				FINISH:		DEBURR AND BREAK SHARP EDGES		DO NOT SCALE DRAWING		REVISION	
DRAWN						TITLE:					
CHK'D						front_structure_assembly_draw					
APPV'D											
MFG											
Q.A											
MATERIAL:						DWG NO.		SCALE:1:10		SHEET 1 OF 1	
WEIGHT:											

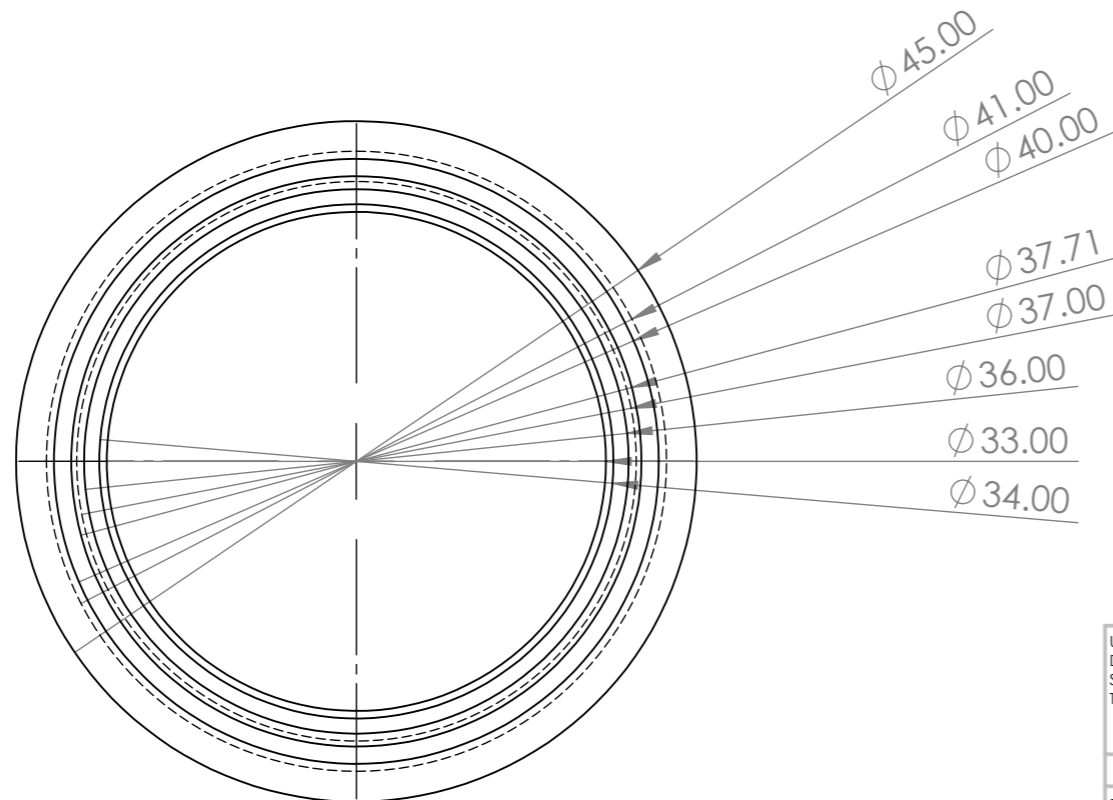
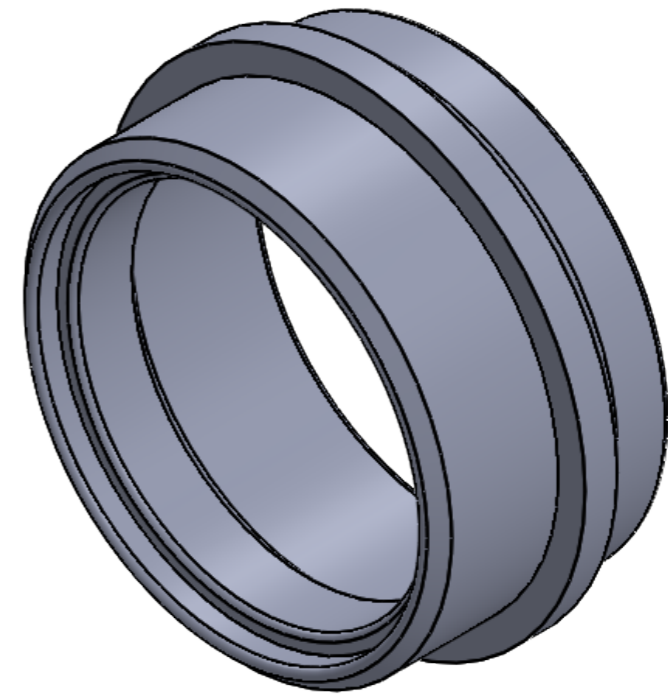
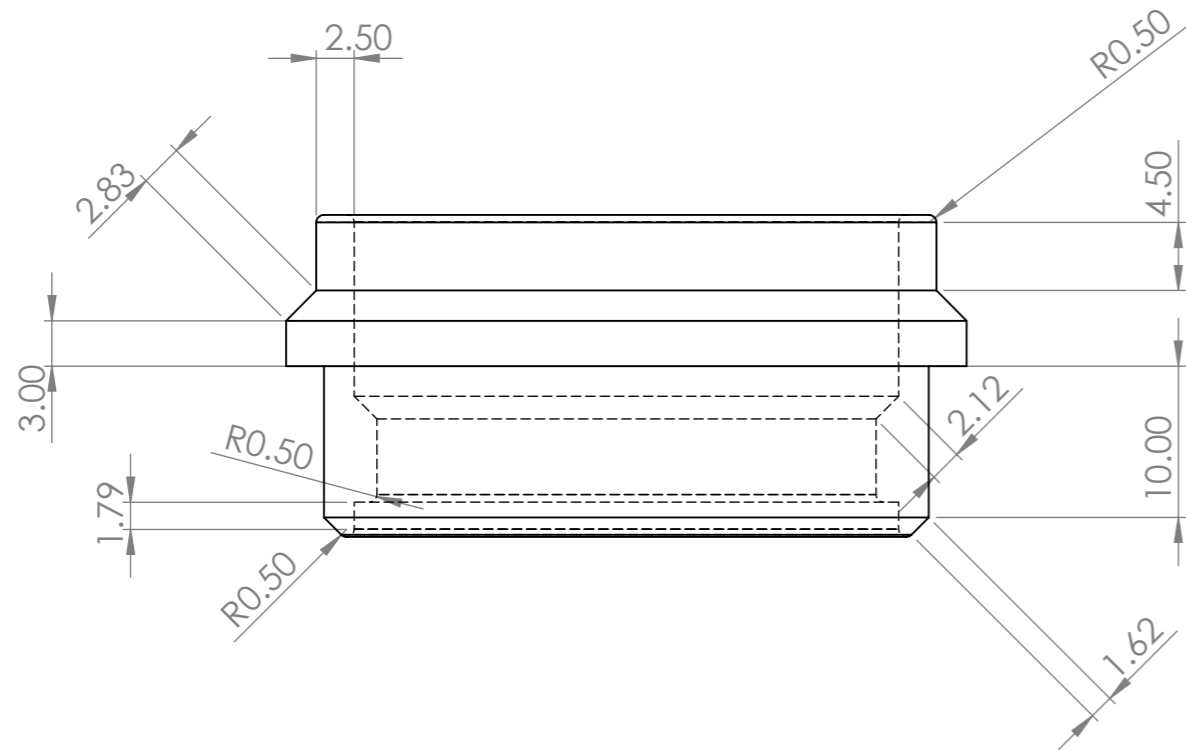

All dimensions are in MM unless stated

UNLESS OTHERWISE SPECIFIED: DIMENSIONS ARE IN MILLIMETERS SURFACE FINISH: TOLERANCES: LINEAR: ANGULAR:		FINISH:	DEBURR AND BREAK SHARP EDGES		DO NOT SCALE DRAWING	REVISION
NAME	SIGNATURE	DATE			TITLE: front_support_ring	
DRAWN Roman Mich					DWG NO. 10	
CHK'D					A3	
APPV'D					SCALE:2:1	
MFG			MATERIAL:		SHEET 1 OF 1	
Q.A			WEIGHT:			

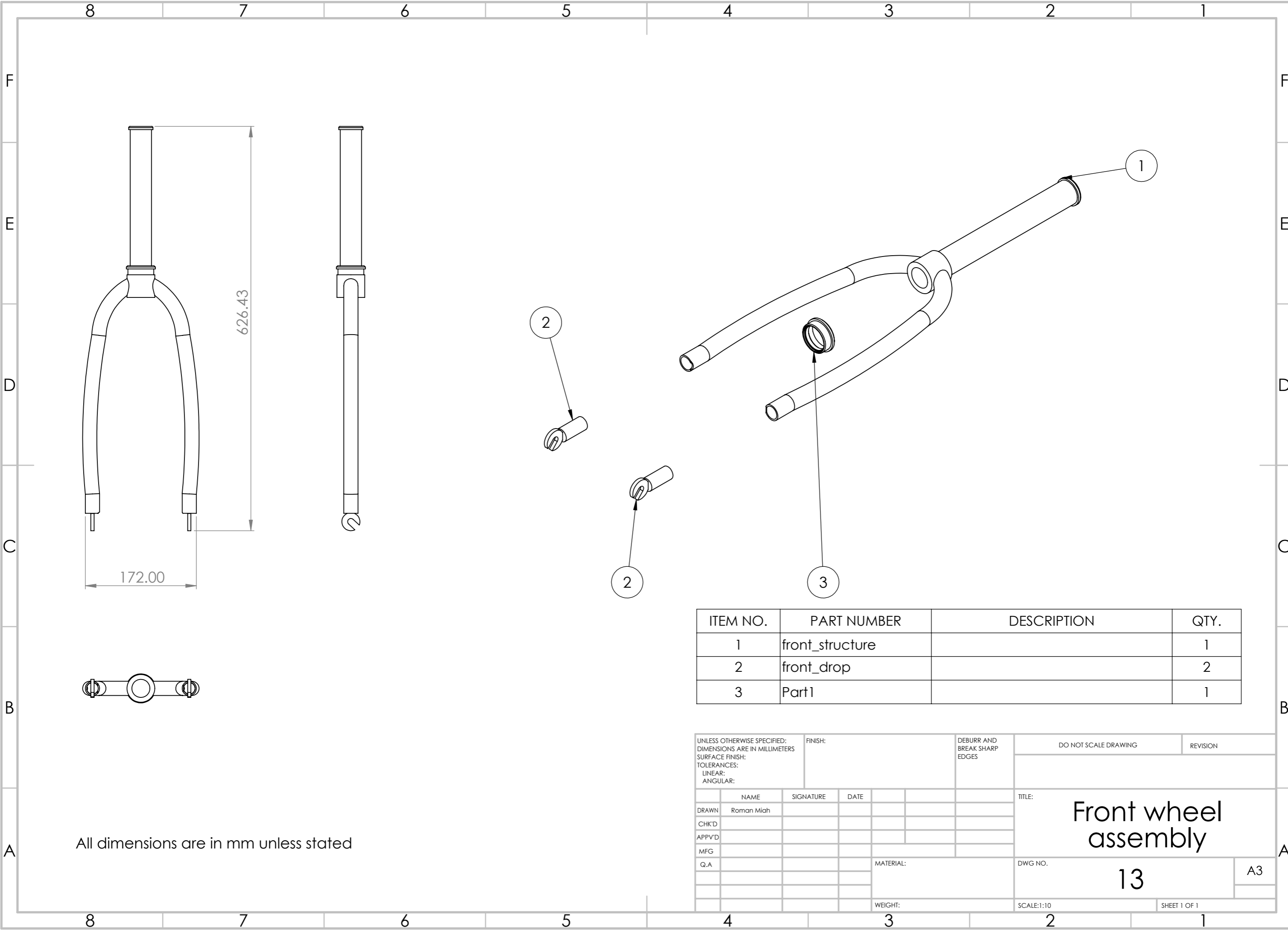

172.00

626.43

ITEM NO.	PART NUMBER	DESCRIPTION	QTY.
1	front_structure		1
2	front_drop		2
3	Part1		1

All dimensions are in mm unless stated

UNLESS OTHERWISE SPECIFIED: DIMENSIONS ARE IN MILLIMETERS SURFACE FINISH: TOLERANCES: LINEAR: ANGULAR:		FINISH:	DEBURR AND BREAK SHARP EDGES	DO NOT SCALE DRAWING	REVISION
NAME	SIGNATURE	DATE		TITLE: Front wheel assembly	
DRAWN Roman Mich				DWG NO. 13	A3
CHK'D				SCALE:1:10	SHEET 1 OF 1
APPV'D					
MFG					
Q.A			MATERIAL:		
			WEIGHT:		

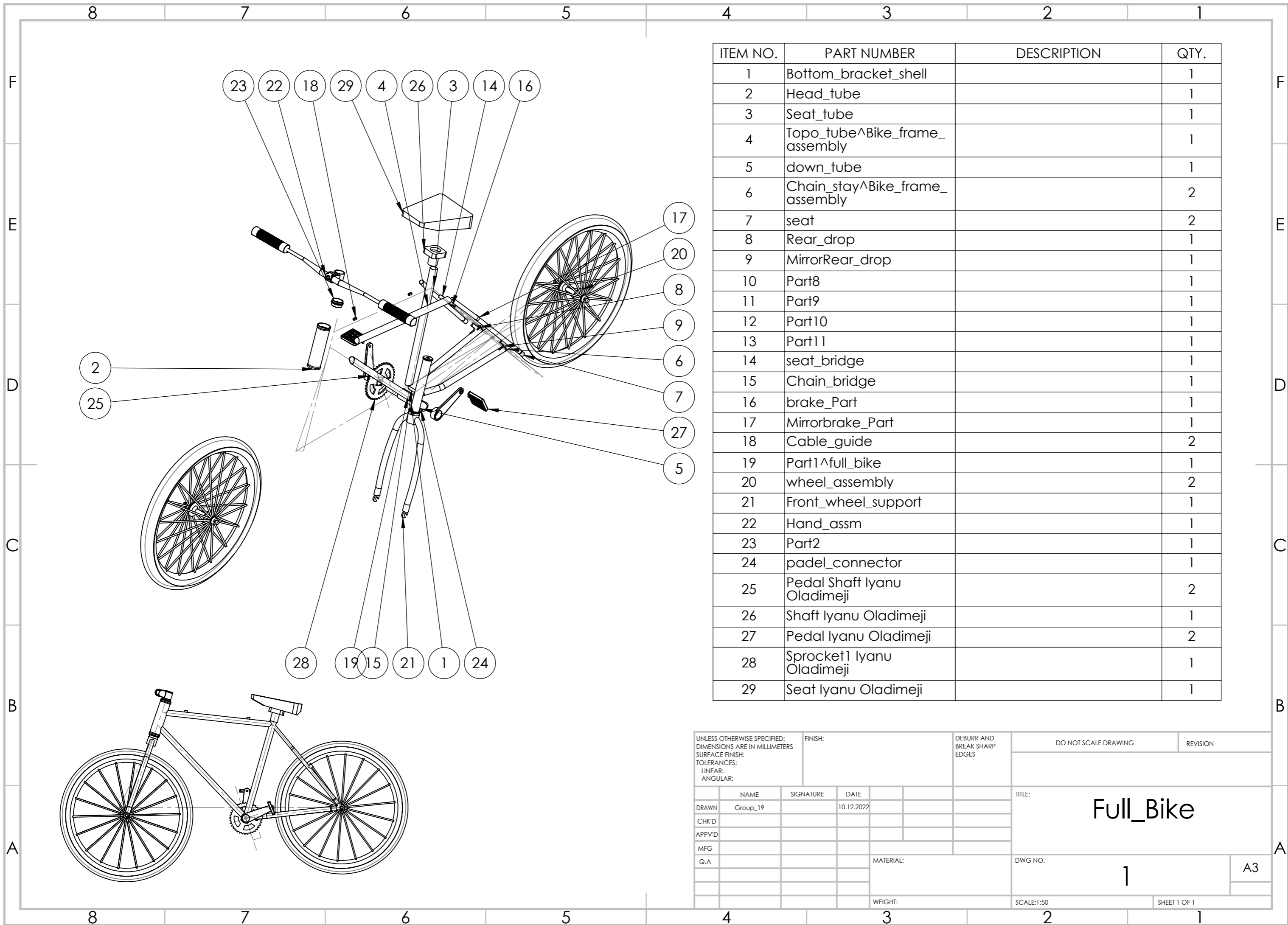

ITEM NO.	PART NUMBER	DESCRIPTION	QTY.
1	Bottom_bracket_shell		1
2	Head_tube		1
3	Seat_tube		1
4	Topo_tube^Bike_frame_assembly		1
5	down_tube		1
6	Chain_stay^Bike_frame_assembly		2
7	seat		2
8	Rear_drop		1
9	MirrorRear_drop		1
10	Part8		1
11	Part9		1
12	Part10		1
13	Part11		1
14	seat_bridge		1
15	Chain_bridge		1
16	brake_Part		1
17	Mirrorbrake_Part		1
18	Cable_guide		2
19	Part1^full_bike		1
20	wheel_assembly		2
21	Front_wheel_support		1
22	Hand_assm		1
23	Part2		1
24	padel_connector		1
25	Pedal Shaft Iyanu Oladimeji		2
26	Shaft Iyanu Oladimeji		1
27	Pedal Iyanu Oladimeji		2
28	Sprocket1 Iyanu Oladimeji		1
29	Seat Iyanu Oladimeji		1

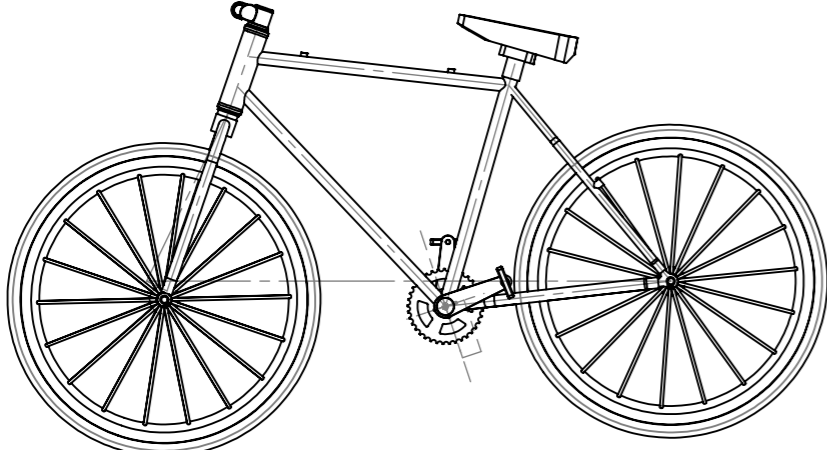

UNLESS OTHERWISE SPECIFIED: DIMENSIONS ARE IN MILLIMETERS SURFACE FINISH: TOLERANCES: LINEAR: ANGULAR:		FINISH:	DEBURR AND BREAK SHARP EDGES	DO NOT SCALE DRAWING	REVISION
NAME	SIGNATURE	DATE	TITLE:	<h1>Full_Bike</h1>	
DRAWN	Group_19	10.12.2022			
CHK'D					
APPV'D					
MFG					
Q.A			MATERIAL:	DWG NO.	1
			WEIGHT:	SCALE:1:50	SHEET 1 OF 1

A3

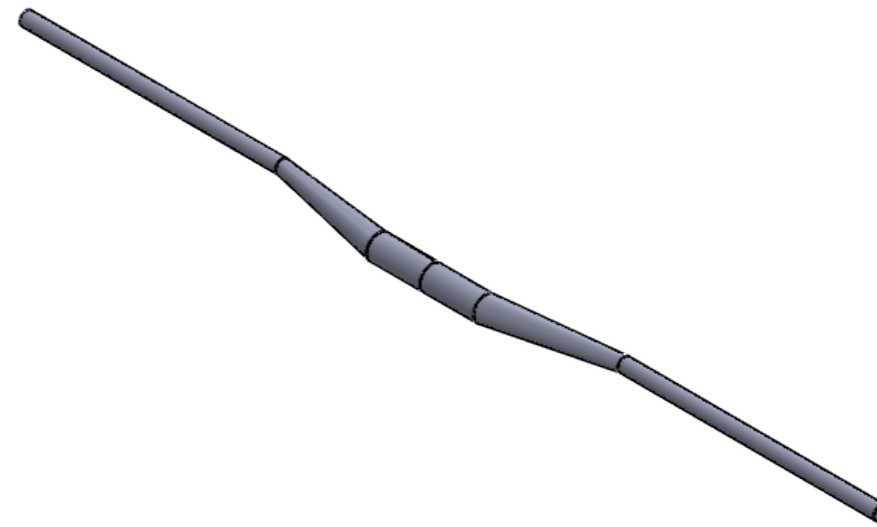
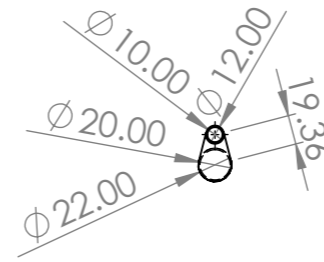
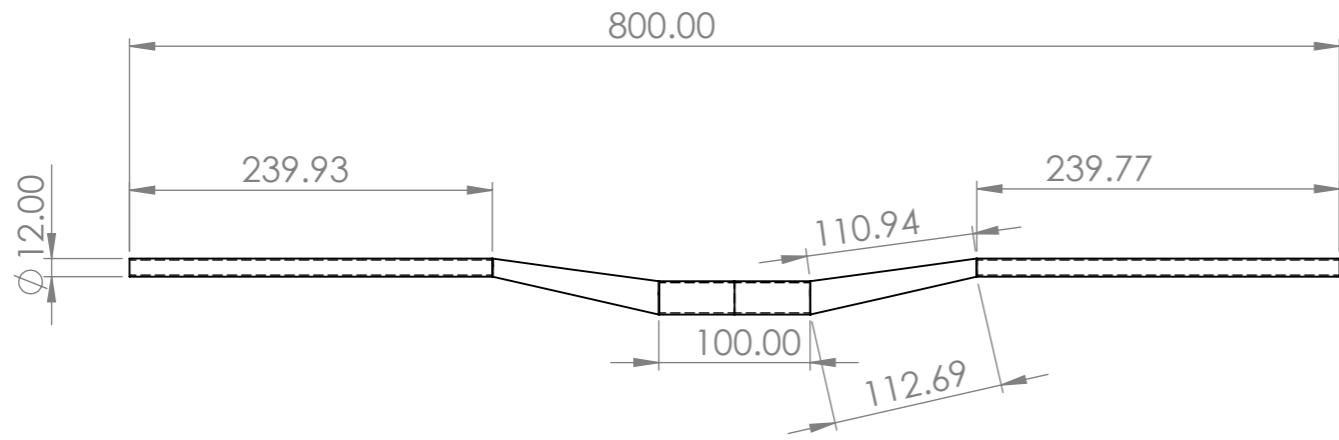

All dimensions are in MM unless stated

UNLESS OTHERWISE SPECIFIED: DIMENSIONS ARE IN MILLIMETERS				FINISH:		DEBURR AND BREAK SHARP EDGES		DO NOT SCALE DRAWING		REVISION	
SURFACE FINISH:								TITLE: Hand shaft			
TOLERANCES:											
LINEAR:											
ANGULAR:											
DRAWN		NAME		SIGNATURE		DATE		DWG NO.		A3	
CHK'D								14			
APPV'D								SCALE:1:5		SHEET 1 OF 1	
MFG								WEIGHT:			
Q.A											

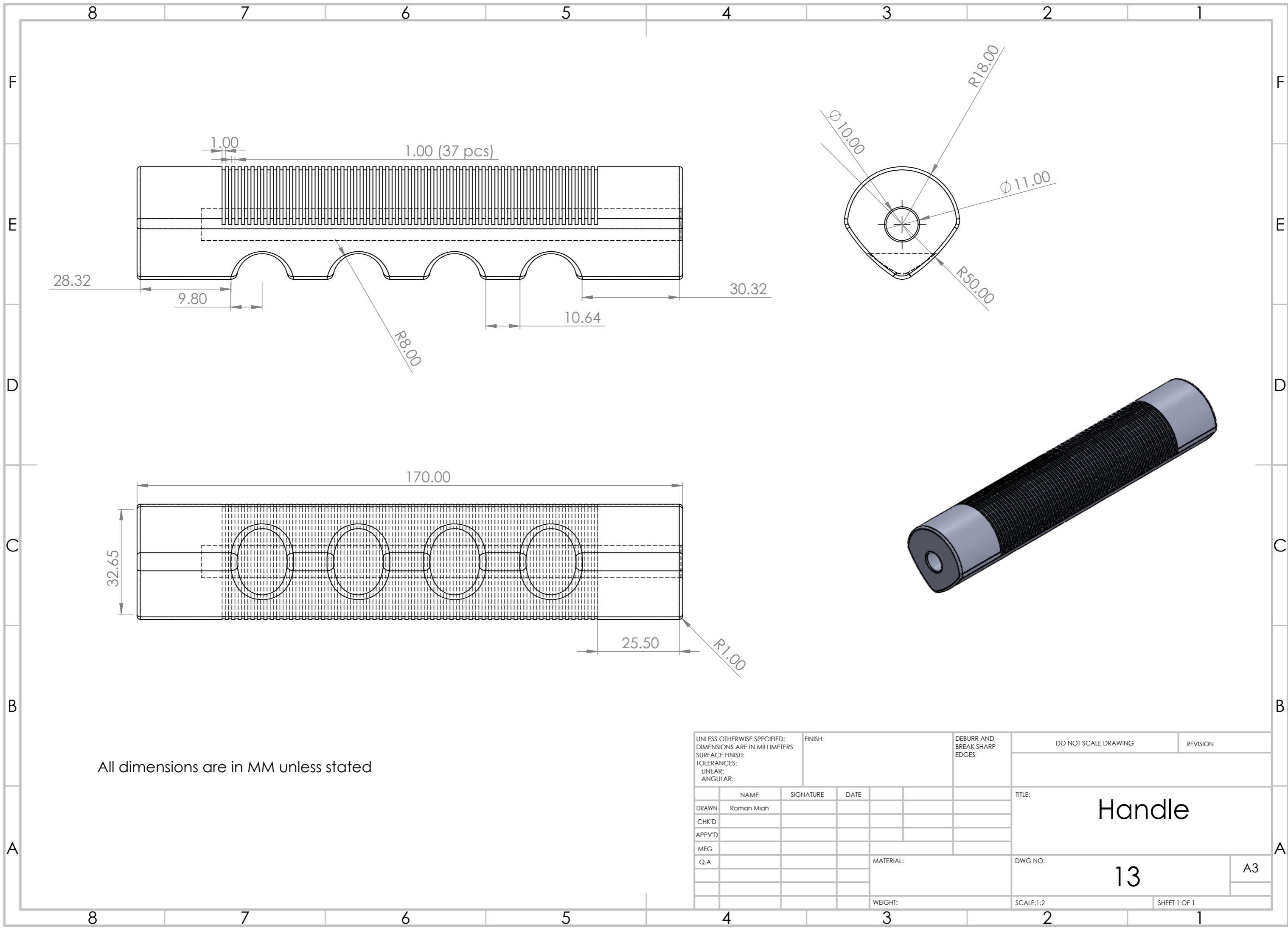

All dimensions are in MM unless stated

UNLESS OTHERWISE SPECIFIED: DIMENSIONS ARE IN MILLIMETERS SURFACE FINISH: TOLERANCES: LINEAR: ANGULAR:			FINISH:		DEBURR AND BREAK SHARP EDGES		DO NOT SCALE DRAWING		REVISION	
DRAWN Roman Mich			SIGNATURE		DATE		TITLE:		Handle	
CHK'D							DWG NO.		13	
APPV'D							SCALE:1:2		SHEET 1 OF 1	
MFG							WEIGHT:		A3	
Q.A							MATERIAL:			

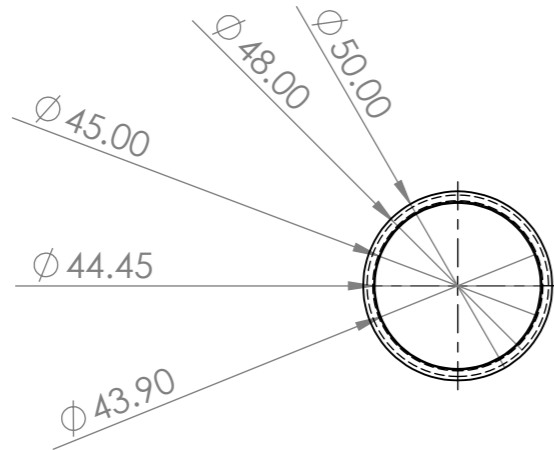
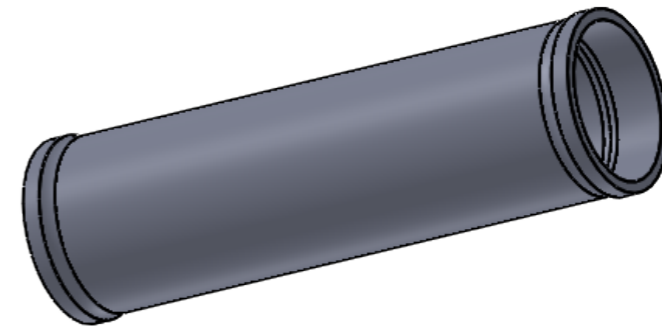
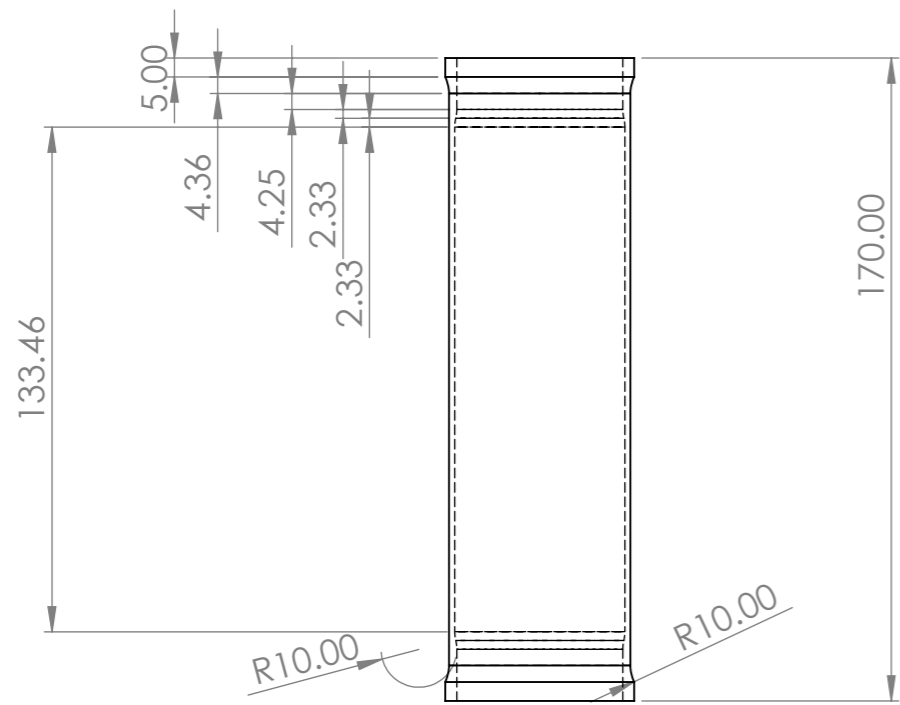

All dimensions are in MM unless stated

UNLESS OTHERWISE SPECIFIED: DIMENSIONS ARE IN MILLIMETERS			FINISH:		DEBURR AND BREAK SHARP EDGES		DO NOT SCALE DRAWING		REVISION	
SURFACE FINISH:										
TOLERANCES:										
LINEAR:										
ANGULAR:										
DRAWN		NAME	SIGNATURE	DATE			TITLE: Head tube			
CHK'D										
APPV'D										
MFG										
Q.A					MATERIAL:		DWG NO. 2		A3	
					WEIGHT:		SCALE:1:2		SHEET 1 OF 1	

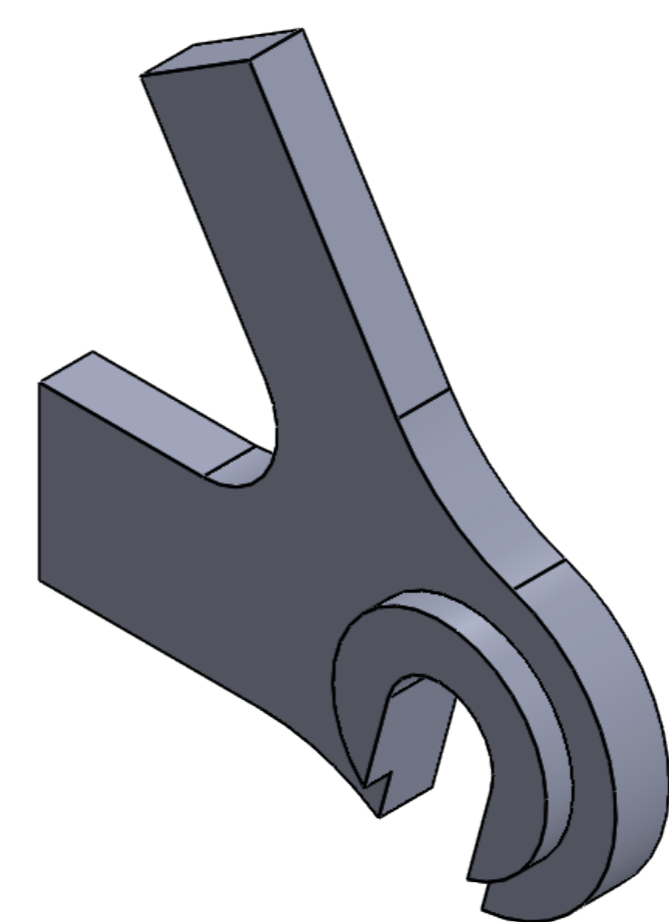
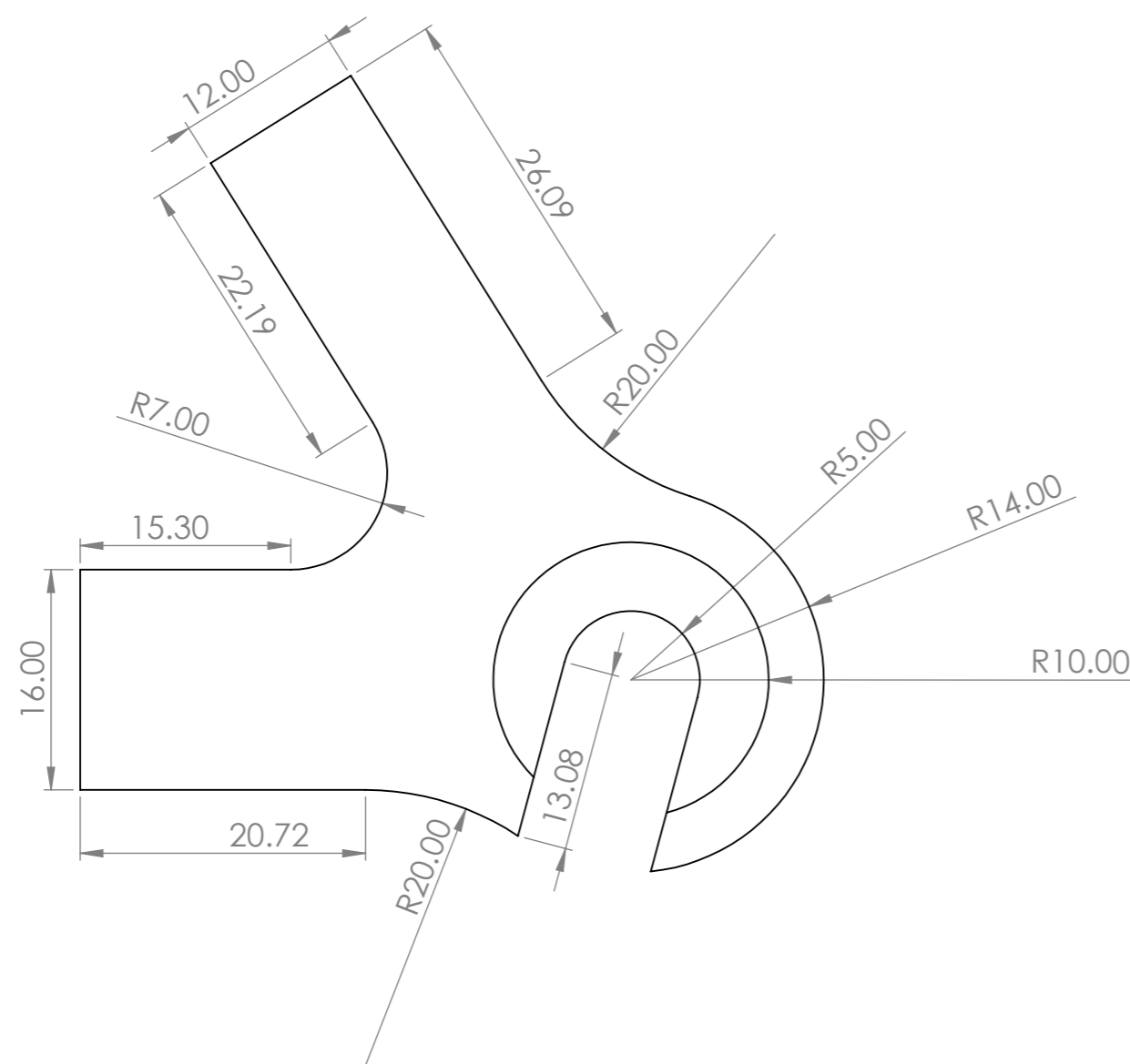

All dimensions are in MM unless stated

UNLESS OTHERWISE SPECIFIED: DIMENSIONS ARE IN MILLIMETERS SURFACE FINISH: TOLERANCES: LINEAR: ANGULAR:			FINISH:		DEBURR AND BREAK SHARP EDGES		DO NOT SCALE DRAWING		REVISION		
DRAWN Roman Mich			SIGNATURE		DATE		TITLE: Rear drop				
CHK'D											
APPV'D											
MFG											
Q.A					MATERIAL:		DWG NO. 7		A3		
					WEIGHT:		SCALE:2:1		SHEET 1 OF 1		

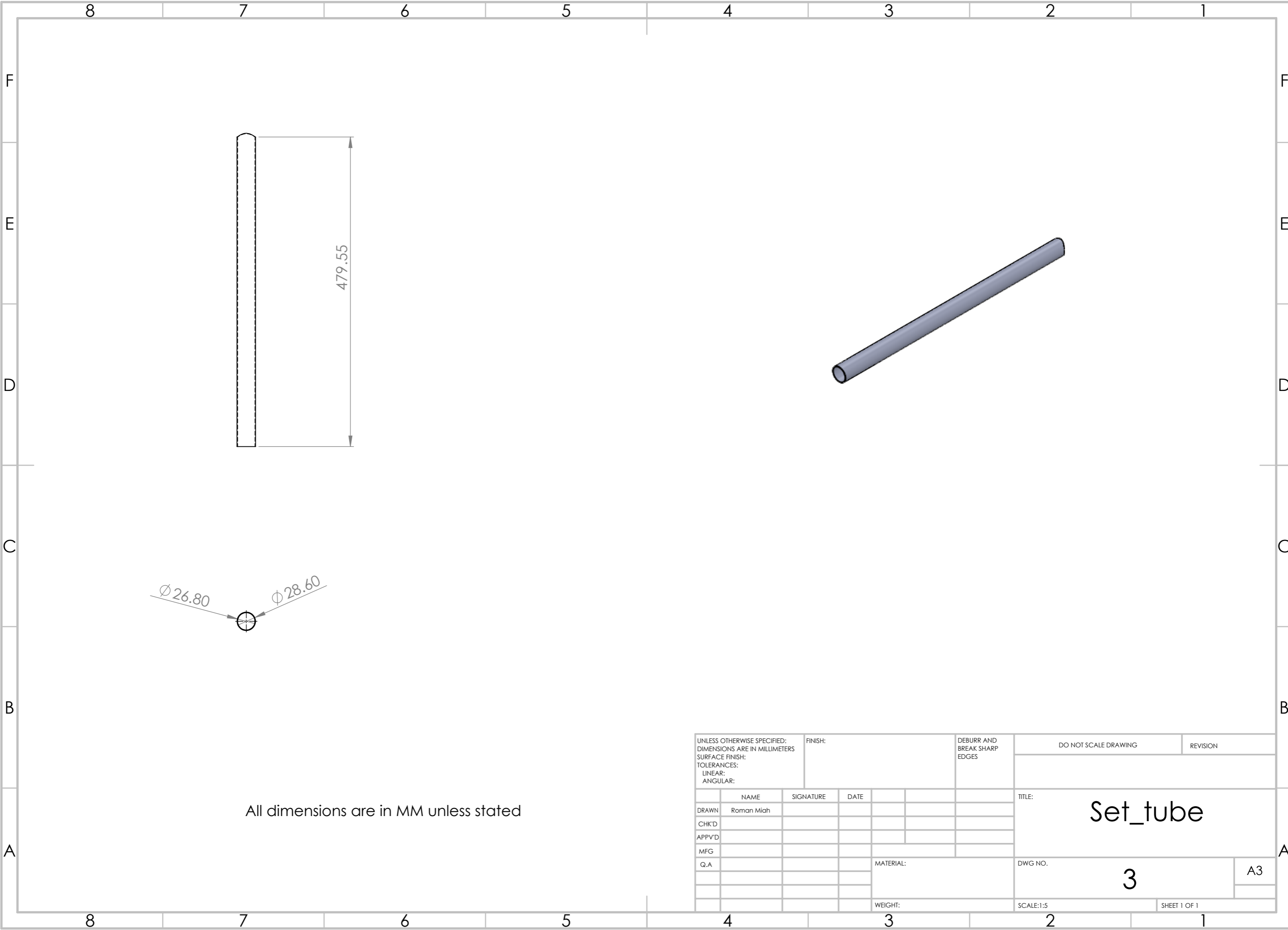

All dimensions are in MM unless stated

UNLESS OTHERWISE SPECIFIED: DIMENSIONS ARE IN MILLIMETERS SURFACE FINISH: TOLERANCES: LINEAR: ANGULAR:				FINISH:		DEBURR AND BREAK SHARP EDGES		DO NOT SCALE DRAWING		REVISION			
								TITLE: Set_tube					
DRAWN				NAME		SIGNATURE						DATE	
CHK'D													
APPV'D													
MFG													
Q.A								MATERIAL:		DWG NO. 3			
								WEIGHT:		SCALE:1:5			
										SHEET 1 OF 1			
										A3			

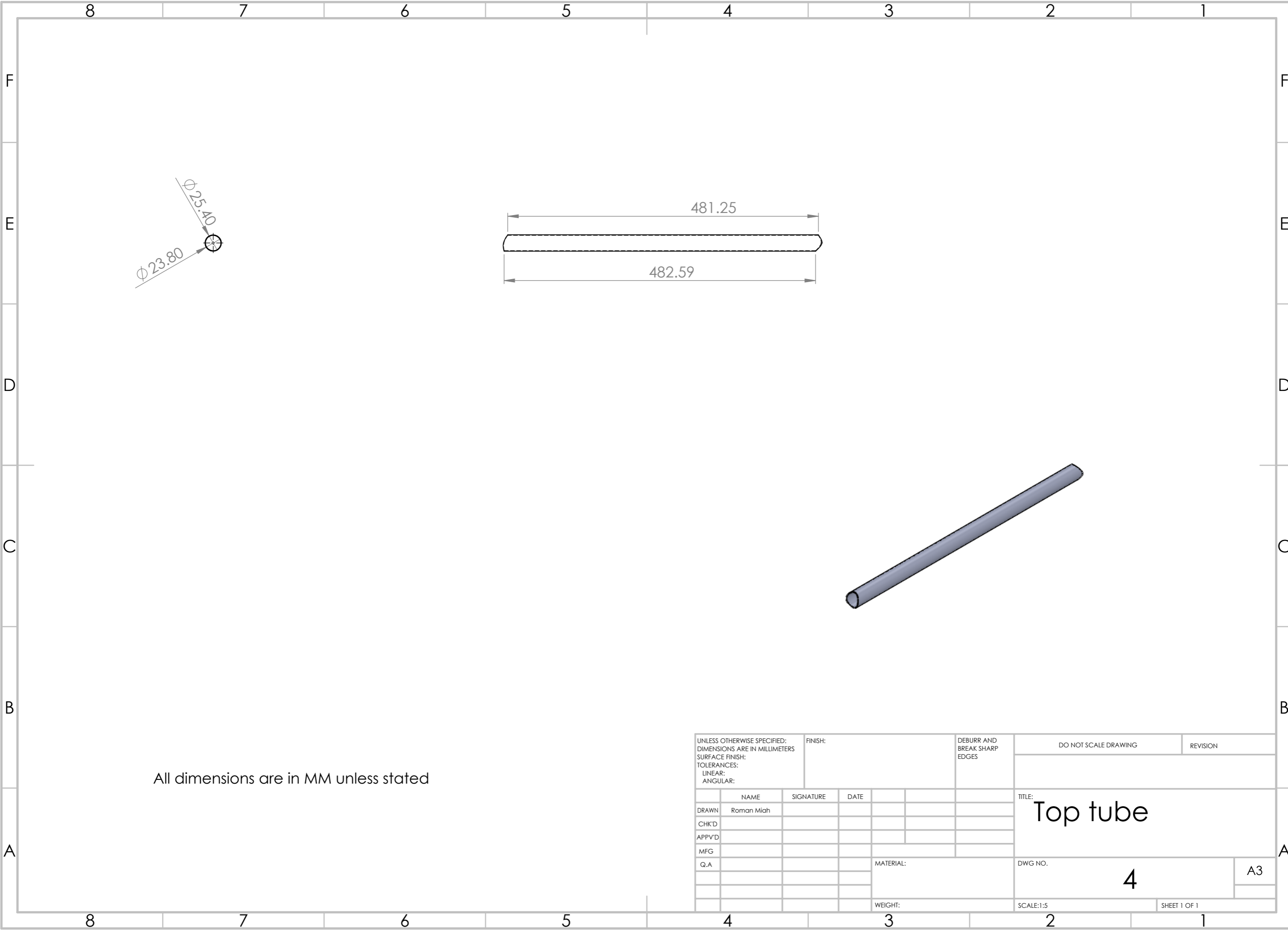

All dimensions are in MM unless stated

UNLESS OTHERWISE SPECIFIED: DIMENSIONS ARE IN MILLIMETERS				FINISH:		DEBURR AND BREAK SHARP EDGES		DO NOT SCALE DRAWING		REVISION	
SURFACE FINISH:								TITLE: Top tube			
TOLERANCES:											
LINEAR:								DWG NO. 4			
ANGULAR:											
DRAWN		NAME		SIGNATURE		DATE		SHEET 1 OF 1			
CHK'D											
APPV'D								SCALE:1:5			
MFG											
Q.A								MATERIAL:			
								WEIGHT:			

A3